

KÖBO

The Chain People

Working hand in hand with the **FOOD INDUSTRY**



MEETING REQUIREMENTS

EXCEEDING EXPECTATIONS



The special requirements of the food and beverage industry are very demanding. Specifications are set through industry standards and with special attention to legal as well as hygienic requirements. KOBO provides state-of-the-art solutions, for instance special acid-resistant and stainless steel chains in maintenance-free execution.

COMPETENT AND RELIABLE PARTNER TO THE FOOD AND BEVERAGE INDUSTRY.

For decades KOBO has provided chain products and technology for the bakery, meat, vegetable, and grain processing industries as well as for the beverage industry. We provide state-of-the-art technology, innovative concepts, and new solutions for the growing complexity and new requirements of the food industry. Our ideas and solutions have set standards.

Benefit from our experience!

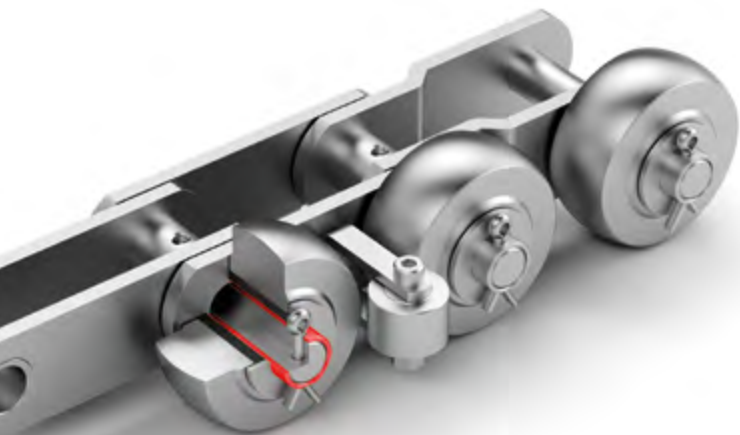

CONVINCING SOLUTIONS CREATED BY KOBO.

We develop, design and manufacture chains and sprockets for the:

bakery industry

grain handling industry

meat processing industry

bottle washing industry

preserve manufacture industry

as well as sprockets for special applications



WE MOVE YOUR BUSINESS



Since 1894 KÖBO has been the name for top-class chain technology. Our high quality standards, constant innovation, state-of-the-art manufacturing, and attention to product safety have made KÖBO a leading supplier of chains and sprockets. Today KÖBO specialists work around the globe to provide effective and innovative solutions:

We are: "The Chain People".

A COLLABORATION THAT WORKS.

Strategic thinking, pragmatic acting, and a distinctive understanding of the requirements in the industry have created our brand. Our chains are well known for their extended lifetime, optimized bearing pressure characteristics, and low friction coefficients - resulting in maximum productivity.



KÖBO Industrial Park Germany

BEST IN CLASS SOLUTIONS AND FIRST CLASS SERVICE.

KÖBO is acting globally. With know-how, experience, top-quality customer service, we create competitive advantages for our customers. Every project is a new challenge. We work hand in hand with our customers to make out the specific requirements and to provide the best solutions for each project. Besides chains and sprockets, KÖBO manufactures attachments, special rollers, buckets as well as pans and single components for specific drive and conveyor solutions.

How can we support you?

CHAINS FOR THE BAKING INDUSTRY

THE RIGHT INGREDIENTS

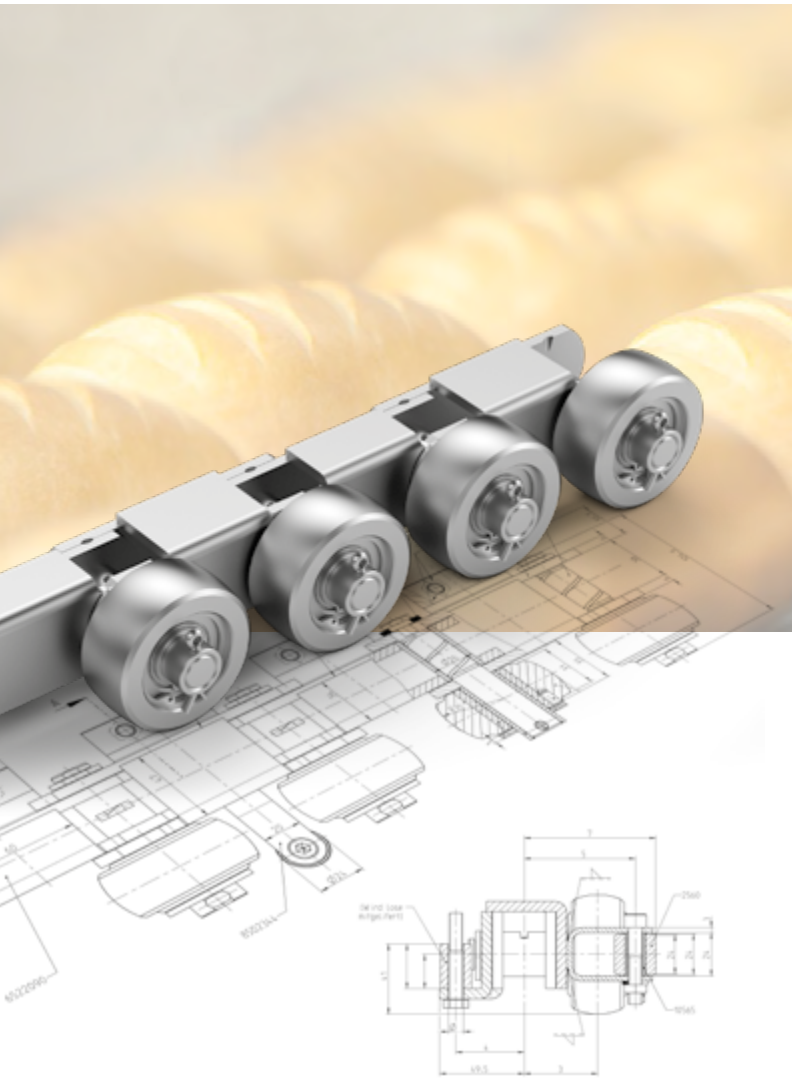

PROOFING CABINETS

PRE-BAKING OVENS

TUNNEL OVENS

THE CONTEMPORARY MODE OF OPERATION.

Many OEMs and end customers rely on our state-of-the-art chain technology. For industrial bakeries such as pizza and bread bakeries, we manufacture special solutions and chains made to order for applications like tunnel ovens, proofing cabinets or pre-baking ovens.

MORE EFFECTIVENESS IN PRODUCTION.

KOBO's research and development together with OEMs and end customers have developed innovative designs. One of those developments are special carbon components. These components have an extended lifetime, are maintenance-free and provide one further advantage: Rollers are mounted outside the chain and can be replaced in very short time saving money and time.



Baking oven chain with flanged roller and high temperature bearing (>600 F).



→ RISING TO FIND SOLUTIONS

THINK PRODUCTS IN A BIGGER WAY.

Proofing cabinet chains are used for sandwich buns.

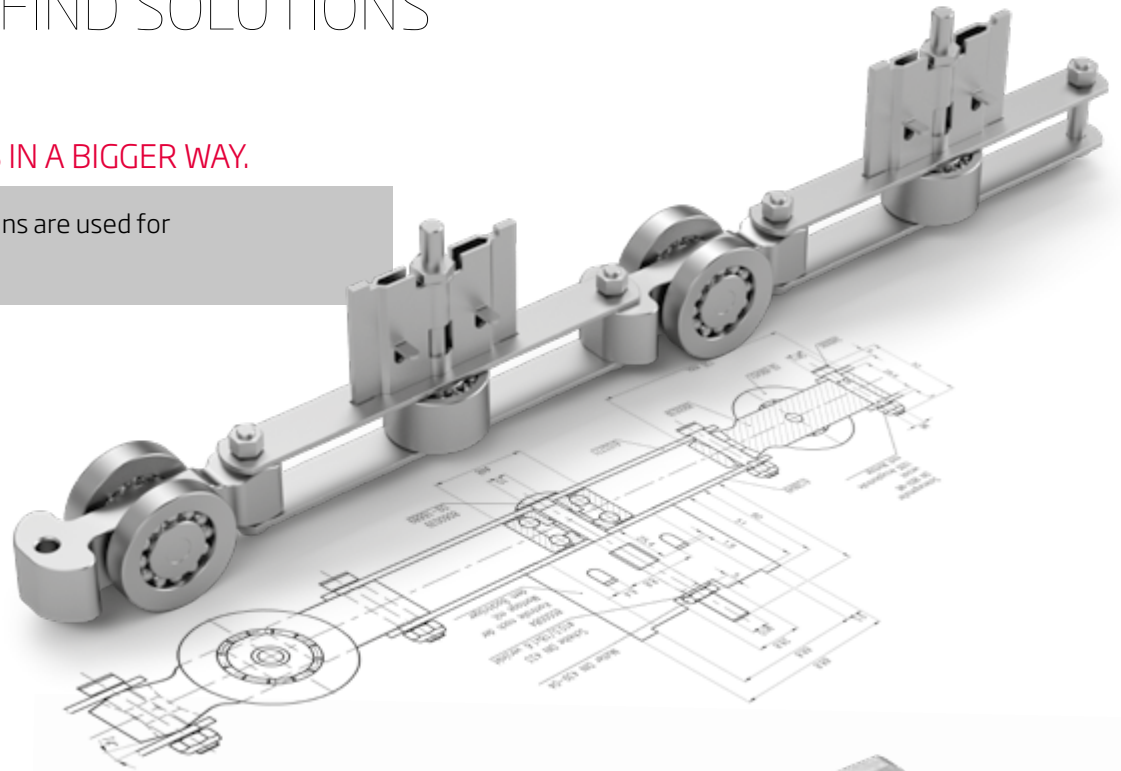

The carbon bushing **FU1087** is the latest development from KÖBO and guarantees longer lifetime due to high bearing pressure characteristics and low friction coefficients.

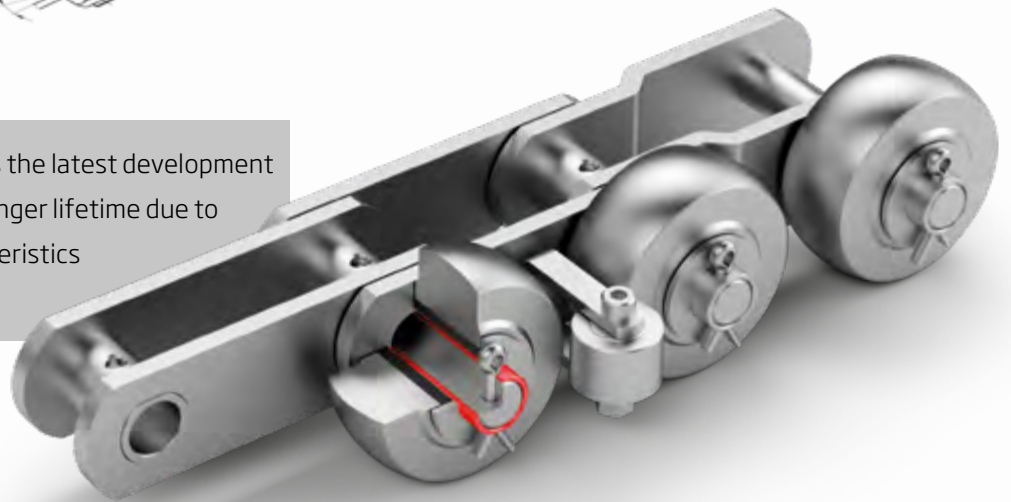

KÖBO carbon bushings stand for:

extended lifetime

low maintenance

easy replacement

availability of different options

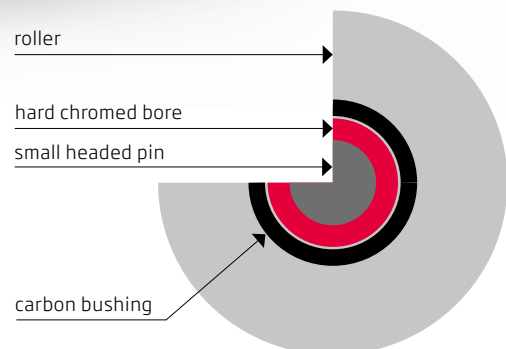

TROUGH CONVEYOR CHAINS

SIMPLE AND RELIABLE QUALITY

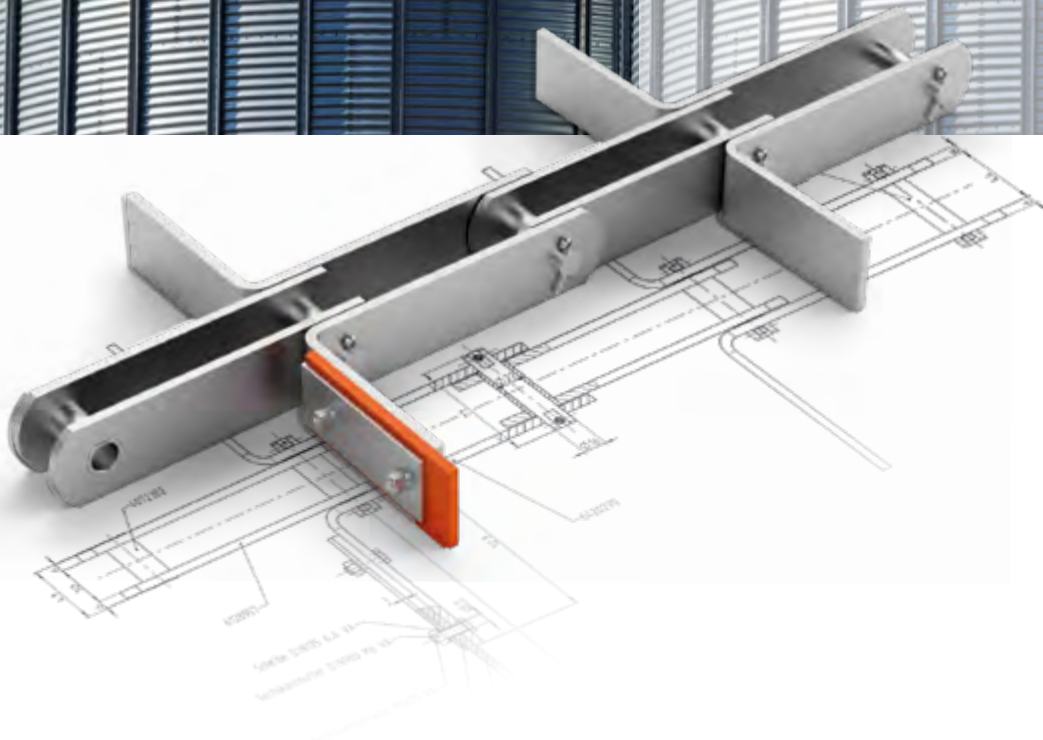

Scraper chain type A (L-formed)

THINKING FORWARD. → MOVING FORWARD.

Trough conveyor chains are used in various applications and different industries, especially in the food industry.

We offer a wide range of trough conveyor chains for various applications.

KOBO's trough conveyor chains are based on the German industry norm [DIN 8165](#) and [DIN 8167](#).

Components and material specifications are chosen according to the special requirements of the conveyor and the transported material. We manufacture the standard range of trough conveyor chains as well as special solutions and custom-made designs.



KÖBO

The Chain People

SLAUGHTERHOUSE CHAIN TECHNOLOGY

CLEANER SOLUTIONS MADE BY KÖBO



BETTER PERSPECTIVE.

The variety of conveyor equipment in the slaughterhouse industry is high. Especially, the hygienic requirements are important to the quality of the conveyor and the final product.

BETTER RESULTS.

Due to KÖBO's cooperation with OEMs and end customers for decades, KÖBO is experienced in the development of the right chains. Customers require long lifetime of conveyors, efficiency in the process, and no downtime in operations. KÖBO offers a wide range of chains such as cardan type chains, u-joint chains or drop-forged chains for overhead conveyors. According to the application, chains can be made with zinc chromate plating or made of stainless steel.

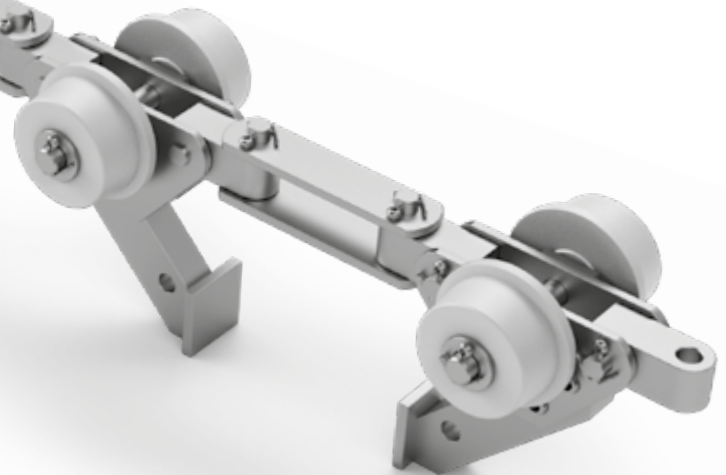

Attachments are developed and manufactured according to the customer's requirement.

BEVERAGE AND BOTTLING

STATE-OF-THE-ART RELIABILITY



Chain for purification in the bottling industry with curved bracket

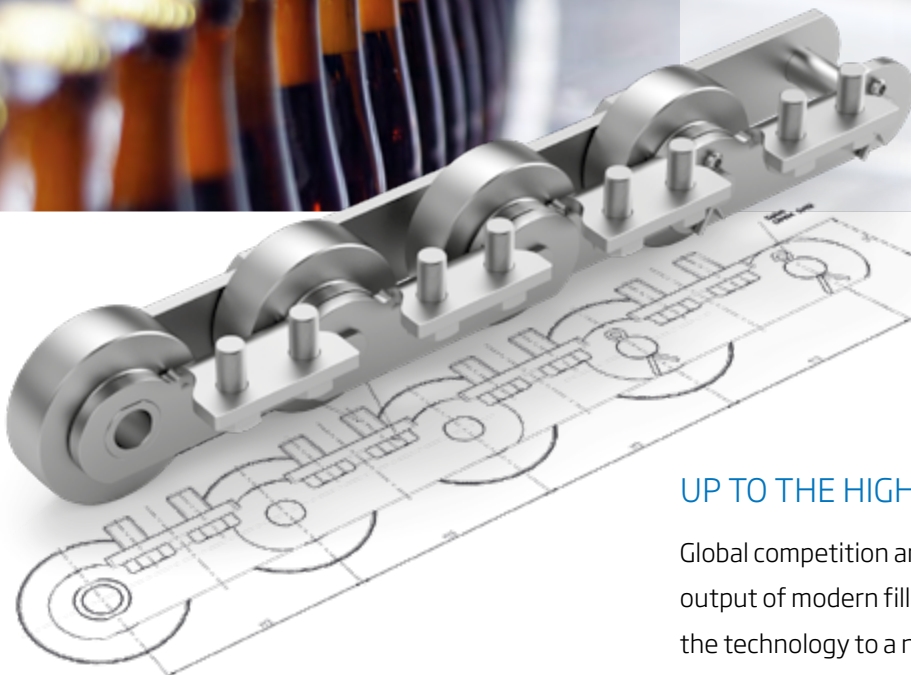

UP TO THE HIGHEST DEMANDS.

Global competition and new innovations increased the output of modern filling systems worldwide and brought the technology to a new level.

This development requires a capacity increase in the bottle cleaning process. KOBO is continuously developing chains with the global leaders in bottle washing technology for longer lifetime and less downtime of the machines.

[We optimize the output of the machines.](#)

EXCEEDING EXPECTATIONS.

Besides standard bottle washing chains, we develop new designs for special applications. Consult with us and we will provide on-site technical assistance.



KÖBO

The Chain People

STERILIZER CHAINS

QUALITY IS A MATTER OF EXPERIENCE



Chain for purification in the bottling industry with permanent welded driver

HIGHER REQUIREMENTS.

The manufacturing process of engineered chains for sterilizing food is very complex. The chains need to meet two requirements: resistance against aggressive media and high temperatures in the working environment. KÖBO's products meet these requirements.

EXTRAORDINARY RESULTS.

State-of-the-art materials are chosen in the manufacturing process of the chains, such as martensitic stainless steel in combination with bronze bushings. Only these materials comply with the high standards of KÖBO engineering.

KÖBO has decades of experience and know-how for economic solutions and long-lasting success.

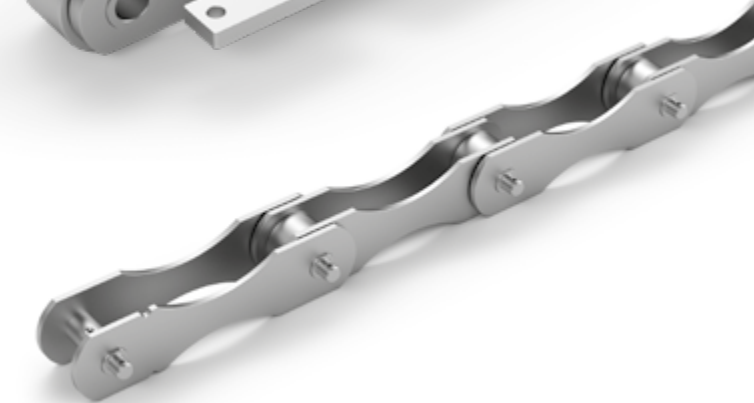

Stainless steel chain for sterilizing vegetables, frozen food, and pet food.

SPROCKETS

SETTING YOUR BUSINESS IN MOTION

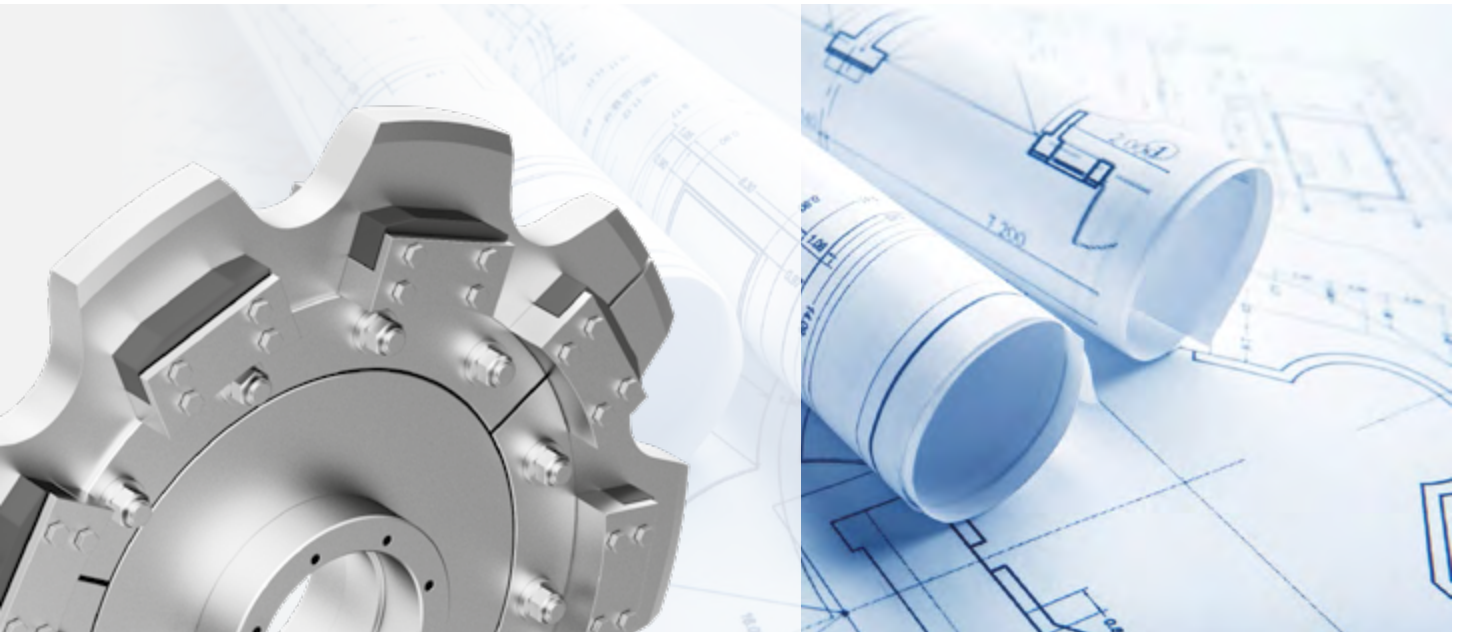

HARD FACTS FOR A BETTER PERFORMANCE.

Chains and sprockets belong together. A chain can only be as good as the sprocket. The quality of the sprockets is critical to the complete drive system.

Therefore, KOBOLD offers different types and shapes of sprockets for almost all applications. Flexibility in operations and special materials, e.g. stainless steel, for special requirements and high-end manufacturing processes like inductive hardening of teeth, are decisive for custom-made solutions.

Sprocket with detachable tooth segment in noise reduction execution



KÖBO

The Chain People

AND IT MOVES ON

Drive sprocket



Split sprocket



KÖBO'S sprocket features:

sprockets with hub on one side or both sides

sprockets with welded on hub

sprockets with keyway

sprockets with thread holes for adjusting screws

sprockets with grooves for dirt-releasing notches

sprockets with increased tooth gap clearance

sprockets with segmental rims

sprockets with induction hardened teeth

SIMPLY MAKING MORE POSSIBLE.

KÖBO manufactures single, duplex or triplex sprockets up to a diameter of 5.5ft.

Standard sprockets, custom-designed sprockets for engineered chains as well as sprockets for roller chains are part of our portfolio.



Our customers can rely on us:

KÖBO is certified acc to DIN EN ISO 9001:2015

KOBO HEADQUARTERS

KÖBO GmbH & Co. KG
Hatzfelder Str. 115
D-42281 Wuppertal
Germany
Tel.: +49 202 7093-0
Fax: +49 202 7093-142
E-Mail: info@koebo.com
www.koebo.com

ASIA

The Chain House / KÖBO Asia
162/2 Phattanakarn Rd. 78
Prawet Parwet 10250 Bangkok
Thailand
Tel.: +66 2321 6913 5
Fax: +66 2321 6916



USA

KOBO USA LLC
370 Great SW Pkwy SW
Suite H, Atlanta, GA 30336
Tel.: +1 630 464 8447
E-Mail: info@kobousa.com
www.kobousa.com

**BRANCH OFFICE CHICAGO /
BRANCH OFFICE MIAMI**

SOUTH AFRICA

Greenstone Hill, Johannesburg
South Africa
Tél. : +27 (0) 836501639
naigel.pera@gmail.com
n.pera@koebo.com
www.koebo.co.za

POLAND OFFICE

Köhler & Bovenkamp Polska
Polska Sp. z o.o.
88-400 Znin ul. Przemysłowa 2
woj. kujawsko-pomorskie
Tel.: +48 52 30 31 36 1
Fax: +48 52 30 31 36 4
E-Mail: marketing@koebo.pl
www.koebo.pl

UK OFFICE

KÖBO (UK) Ltd. Ketten House
Leestone Road,
Sharston Industrial Area,
GB-Manchester, M22 4RB
Tel.: +44 (0)161 491 9840
Fax: +44 (0)161 428 1999
E-Mail: info@kobo.co.uk
www.kobo.co.uk

FRANCE OFFICE

KÖBO France S.A.R.L.
6 rue du Chant des Oiseaux
F-78360 Montesson
Tel.: +33 1 30 15 24 50
Fax: +33 1 34 80 16 50
E-Mail: kobo.france@wanadoo.fr
www.koebo.com/fr

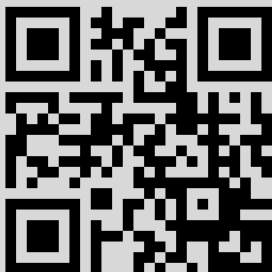

MEETING REQUIREMENTS.
→ EXCEEDING EXPECTATIONS.